

# ELBOWS

ASME B16.9

Buttweld Fittings

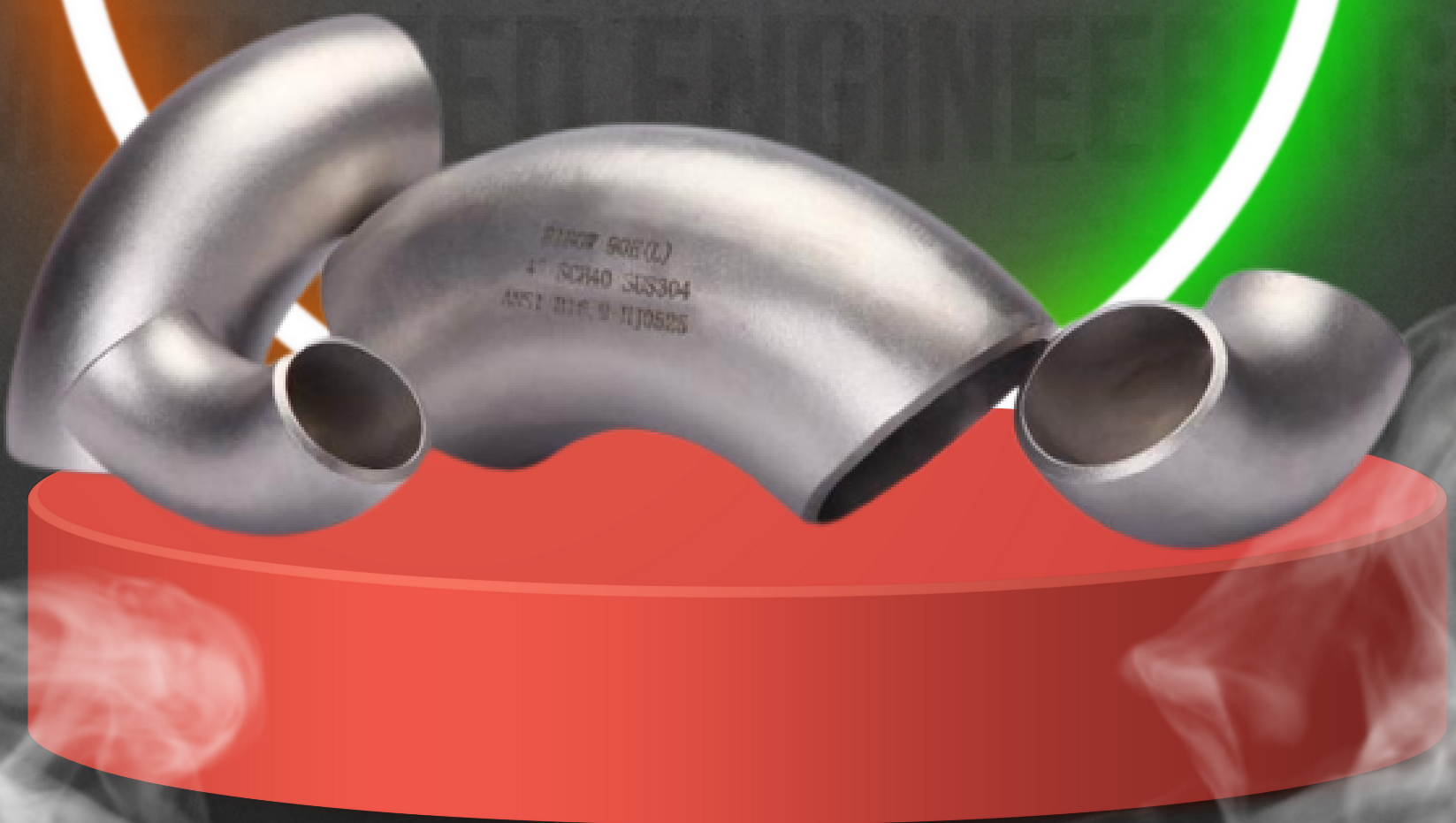

**MANUFACTURERS**

[WWW.METALFED.COM](http://WWW.METALFED.COM)

# DIMENSIONS

## 45°-90° LR AND 3D ASME B16.9 ELBOWS

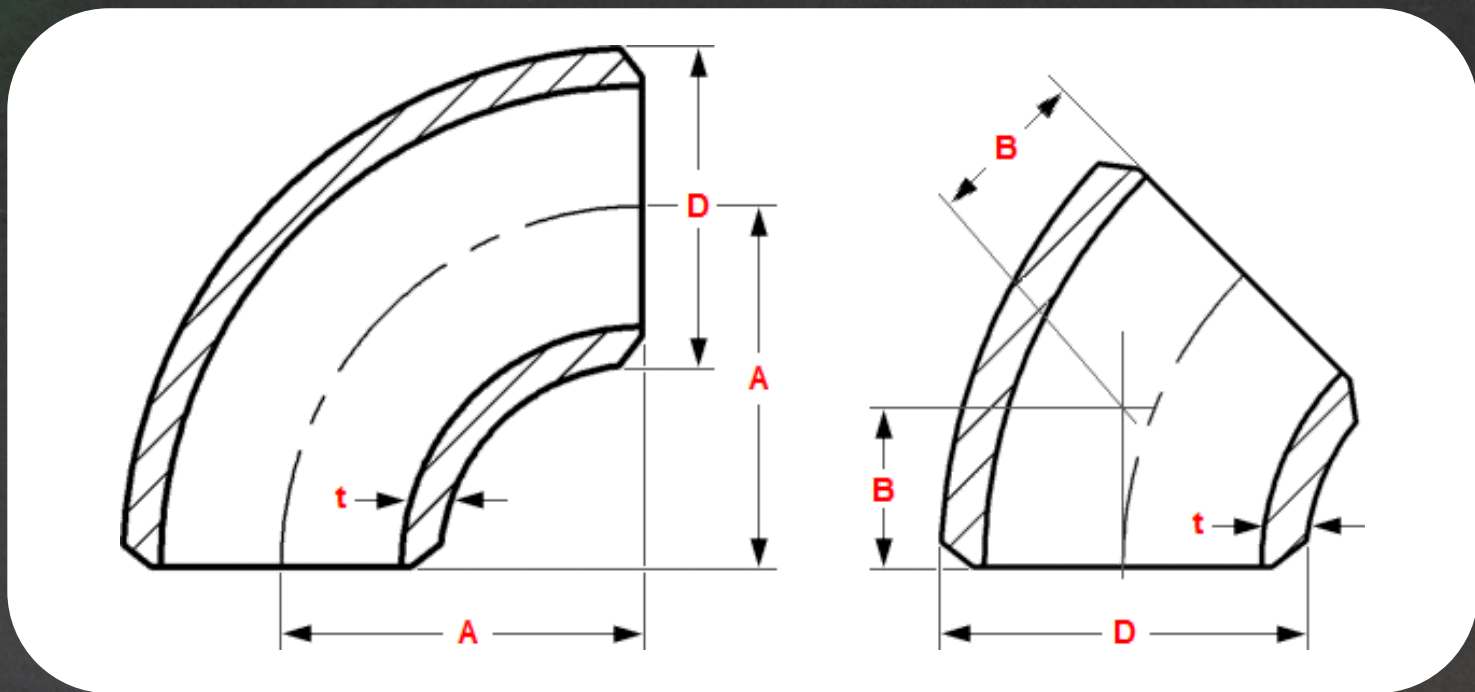

NPS	O.D.D	90° LRA	45° LRB	90° 3DA	45° 3DB
1/2	21.3	38	16		
3/4	26.7	38	19	57	24
1	33.4	38	22	76	31
1 1/4	42.2	48	25	95	39
1 1/2	48.3	57	29	114	47
2	60.3	76	35	152	63
2 1/2	73	95	44	190	79
3	88.9	114	51	229	95
3 1/2	101.6	133	57	267	111
4	114.3	152	64	305	127
5	141.3	190	79	381	157
6	168.3	229	95	457	189
8	219.1	305	127	610	252
10	273	381	159	762	316
12	323.8	457	190	914	378
14	355.6	533	222	1067	441
16	406.4	610	254	1219	505
18	457	686	286	1372	568
20	508	762	318	1524	632
22	559	838	343	1676	694
24	610	914	381	1829	757
26	660	991	406	1981	821
28	711	1067	438	2134	883
30	762	1143	470	2286	946
32	813	1219	502	2438	1010
34	864	1295	533	2591	1073
36	914	1372	565	2743	1135
38	965	1448	600	2896	1200
40	1016	1524	632	3048	1264
42	1067	1600	660	3200	1326
44	1118	1676	695	3353	1389
46	1168	1753	727	3505	1453
48	1219	1829	759	3658	1516

Dimensions are in millimeters unless otherwise indicated. Wall thickness (t) must be specified by customer. A & B are Center to End dimensions

[WWW.METALFED.COM](http://WWW.METALFED.COM)

# TOLERANCES

## DIMENSIONAL TOLERANCES OF BUTT WELD ELBOWS 45° & 90° LR & 3D ASME B16.9

Nominal Pipe Size	1/2 to 2.1/2	3 to 3.1/2	4	5 to 8
Outside Diameter at Bevel (D)	+ 1.6- 0.8	1.6	1.6	+ 2.4- 1.6
Inside Diameter at End	0.8	1.6	1.6	1.6
Center to End LR (A/B)	2	2	2	2
Center to End 3D (A/B)	3	3	3	3
Nominal Pipe Size	10 to 18	20 to 24	26 to 30	32 to 48
Outside Diameter at Bevel (D)	+ 4- 3.2	+ 6.4- 4.8	+ 6.4- 4.8	+ 6.4- 4.8
Inside Diameter at End	3.2	4.8	+ 6.4- 4.8	+ 6.4- 4.8
Center to End LR (A/B)	2	2	3	5
Center to End 3D (A/B)	3	3	6	6
Wall Thickness (t)	Not less than 87.5% of Nominal Wall Thickness			

Dimensional tolerances are in millimeters unless otherwise indicated and are equal ± except as noted.

### Note..

MSS SP-43 only covers stainless steel butt weld fittings made for use with Schedule 5S and 10S pipe and Stub Ends suitable for use with Schedule 40S pipe, as defined in ASME B36.19. The dimensions and dimensional tolerances defined in MSS SP-43 are substantially the same as those in ASME B16.9 specifications from NPS 1/2 - NPS 24. Except with regard to the outside diameter at the bevel.